



USB 2.0 Mobile Disk

M1 Type Specification

Version 1.0

本文件為勤茂資通(股)有限公司專有之財產，非經書面許可，不准透露或使用本文件，亦不准複製或轉變成任何其他形式使用。如有任何修改恕不另行通知

The information contained herein is the exclusive property of TwinMOS Technologies Inc. and shall not be distributed, reproduced, or disclosed in whole or in part without prior written permission of TwinMOS Technologies Inc. TwinMOS Technologies Inc reserved the right to make changes without ant prior notice. <http://www.twinmos.com>

Contents

A. Product Outline	3
B. System Features	4
C. Block Diagram	5
D. Electrical Specifications	6
E. Housing Dimension Diagram	8

Revision History

Version	Date	Description

本文件為勤茂資通(股)有限公司專有之財產，非經書面許可，不准透露或使用本文件，亦不准複製或轉變成任何其他形式使用。如有任何修改恕不另行通知

The information contained herein is the exclusive property of TwinMOS Technologies Inc. and shall not be distributed, reproduced, or disclosed in whole or in part without prior written permission of TwinMOS Technologies Inc. TwinMOS Technologies Inc reserved the right to make changes without ant prior notice. <http://www.twinmos.com>

A. General Description :

PC based mass storage product with the capability of file & directory read & write function through USB connection. Easy carry and transport final product with manual write protection function. Mobile Disk can be partitioned into public and/or security area by the application software . Only one partition (public or security area) can be seen at one time with a predefined password to switch areas.

本文件為勤茂資通(股)有限公司專有之財產，非經書面許可，不准透露或使用本文件，亦不准複製或轉變成任何其他形式使用。如有任何修改恕不另行通知

The information contained herein is the exclusive property of TwinMOS Technologies Inc. and shall not be distributed, reproduced, or disclosed in whole or in part without prior written permission of TwinMOS Technologies Inc. TwinMOS Technologies Inc reserved the right to make changes without ant prior notice. <http://www.twinmos.com>



B. Product Feature :

- Mass storage class controller with Universal Serial Bus interface
- USB Specification Compliance
 - Conforms to high-speed (480Mb/s) USB Specification, Version 2.0
 - Meet bus power specification
- Write-protected ability
- Higher reliability: ECC on the fly
- Automatic bad block management
- Supported OS:
 - Win XP, Win2000, Windows ME, Linux 2.4 above, and MAC OS 9.0 & higher
 - Win 98/Win98SE driver available
 - Mac 8.6 mass storage driver available from Apple
- Multiple LUN Windows driver is available
- LED indication: Suspend, Active, Idle modes.
- Recommended operating temperature : 0 – 85°C
- Connector durability: Testing to 10000 cycles.

本文件為勤茂資通(股)有限公司專有之財產，非經書面許可，不准透露或使用本文件，亦不准複製或轉變成任何其他形式使用。如有任何修改恕不另行通知

The information contained herein is the exclusive property of TwinMOS Technologies Inc. and shall not be distributed, reproduced, or disclosed in whole or in part without prior written permission of TwinMOS Technologies Inc. TwinMOS Technologies Inc reserved the right to make changes without ant prior notice. <http://www.twinmos.com>

C. Block Diagram

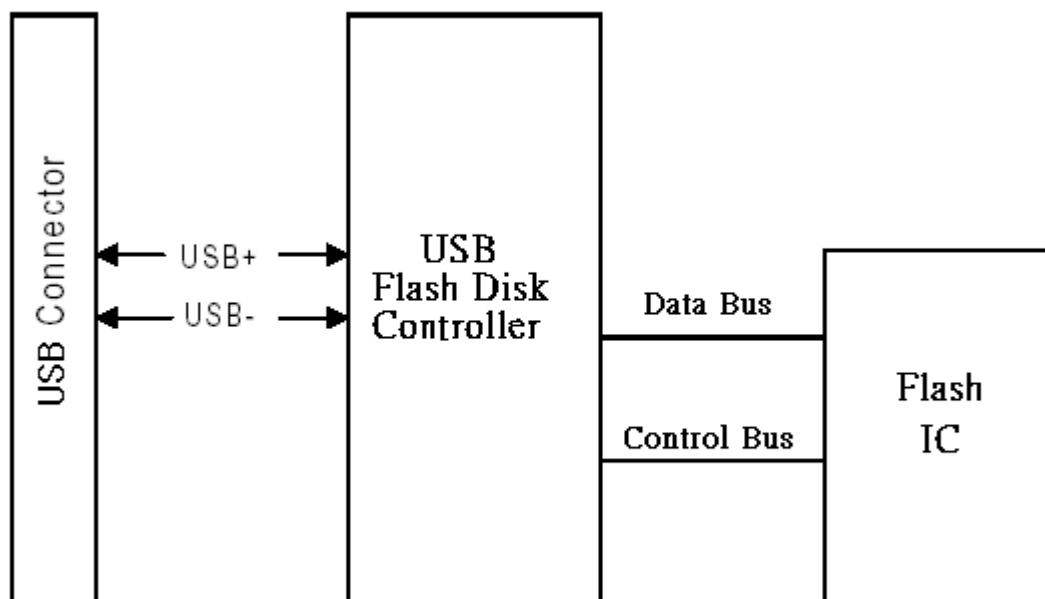

本文件為勤茂資通(股)有限公司專有之財產，非經書面許可，不准透露或使用本文件，亦不准複製或轉變成任何其他形式使用。如有任何修改恕不另行通知

The information contained herein is the exclusive property of TwinMOS Technologies Inc. and shall not be distributed, reproduced, or disclosed in whole or in part without prior written permission of TwinMOS Technologies Inc. TwinMOS Technologies Inc reserved the right to make changes without ant prior notice. <http://www.twinmos.com>



D. Electrical Specifications

■ Absolute Maximum Ratings:

Symbol	Parameter	Min	Max	Unit	Notes
Tstorage	Storage Temperature	-40	85	°C	
Ta	Ambient Operating Temperature	0	75	°C	
Vcc3	3.3V Supply Voltage	-0.3	3.6	V	
Vcc18	1.8V Supply Voltage	-0.3	2	V	
Vin3.3	3.3V Buffer Input Voltage	-0.3	3.6	V	
Vin3/5	3.3V/5V Buffer Input Voltage	-0.3	5	V	
Vin1.8	1.8V Buffer Input Voltage	-0.3	2	V	

DC Characteristics

Unless otherwise noted, all test conditions are as follows:

Gnd=0V, Vcc33=3.3V±5%, Vcc18=1.8V±5%

Table 2 DC Characteristics of I/O Interface

Symbol	Parameter	Min	Max	Unit	Notes
V _{IH_TTL}	TTL Input High Voltage	2	Vcc3+0.3	V	1
V _{IL_TTL}	TTL Input Low Voltage	-0.3	0.8	V	1
V _{OH_TTL}	TTL Output High Voltage	0.9Vcc3		V	1
V _{OL_TTL}	TTL Output Low Voltage		0.45	V	1
I _{OH_TTL}	TTL Output High Current	-4		mA	1
I _{OL_TTL}	TTL Output Low Current		4	mA	1
V _{IH_USB}	USB Input High Voltage for Low-/full-speed	2.0		V	2
V _{IL_USB}	USB Input Low Voltage for Low-/full-speed		0.8	V	2
V _{I_USB_DIFF}	Differential Input Sensitivity for Low-/full-speed	TBD		V	2
V _{I_USB_CM}	Differential Common Mode Input Range for Low-/full-speed	0.8	2.5	V	2
V _{I_USB_HSSQ}	USB High-speed squelch Input detection threshold	0.1	0.15	V	2
V _{I_USB_HSDSC}	USB High-speed disconnect Input detection threshold	0.525	0.625	V	2

本文件為勤茂資通(股)有限公司專有之財產，非經書面許可，不准透露或使用本文件，亦不准複製或轉變成任何其他形式使用。如有任何修改恕不另行通知

The information contained herein is the exclusive property of TwinMOS Technologies Inc. and shall not be distributed, reproduced, or disclosed in whole or in part without prior written permission of TwinMOS Technologies Inc. TwinMOS Technologies Inc reserved the right to make changes without ant prior notice.

<http://www.twinmos.com>



Symbol	Parameter	Min	Max	Unit	Notes
	Common Mode Range				
V _{OH_USB}	USB Output High Voltage for Low-/full-speed	2.8	3.6	V	2
V _{OL_USB}	USB Output Low Voltage for Low-/full-speed	0	0.3	V	2
V _{OH_USB_HS}	USB Output High Voltage for High-speed	0.36	0.44	V	2
V _{OL_USB_HS}	USB Output Low Voltage for High-speed	-0.01	0.01	V	2
I _{OH_USB}	USB Output High Current for Low-/full-speed	-10		mA	2
I _{OL_USB}	USB Output Low Current for Low-/full-speed		10	mA	2
I _{OH_USB_HS}	USB Output High Current for High-speed	-40		mA	2
I _{OL_USB_HS}	USB Output Low Current for High-speed		40	mA	2

AC Characteristics

Symbol	Parameter	Min.	Typ.	Max.	Unit
TP _{ILH}	Input Rising Delay	0.61 (0.8pF)	0.72 (2.4pF)	0.92 (4.8pF)	ns
TP _{IHL}	Input falling Delay	0.88 (0.8pF)	1.03 (2.4pF)	1.24 (4.8pF)	ns
TP _{OLH}	Output Rising Delay	2.40 (10pF)	3.42 (30pF)	4.88 (60pF)	ns
TP _{OHL}	Output falling Delay	2.61 (10pF)	3.62 (30pF)	5.03 (60pF)	ns
TR	Output Rising Time	2.26 (10pF)	4.45 (30pF)	7.83 (60pF)	ns
TF	Output falling Time	1.90 (10pF)	3.63 (30pF)	6.23 (60pF)	ns

本文件為勤茂資通(股)有限公司專有之財產，非經書面許可，不准透露或使用本文件，亦不准複製或轉變成任何其他形式使用。如有任何修改恕不另行通知

The information contained herein is the exclusive property of TwinMOS Technologies Inc. and shall not be distributed, reproduced, or disclosed in whole or in part without prior written permission of TwinMOS Technologies Inc. TwinMOS Technologies Inc reserved the right to make changes without ant prior notice. <http://www.twinmos.com>



F. Housing Dimension Diagram

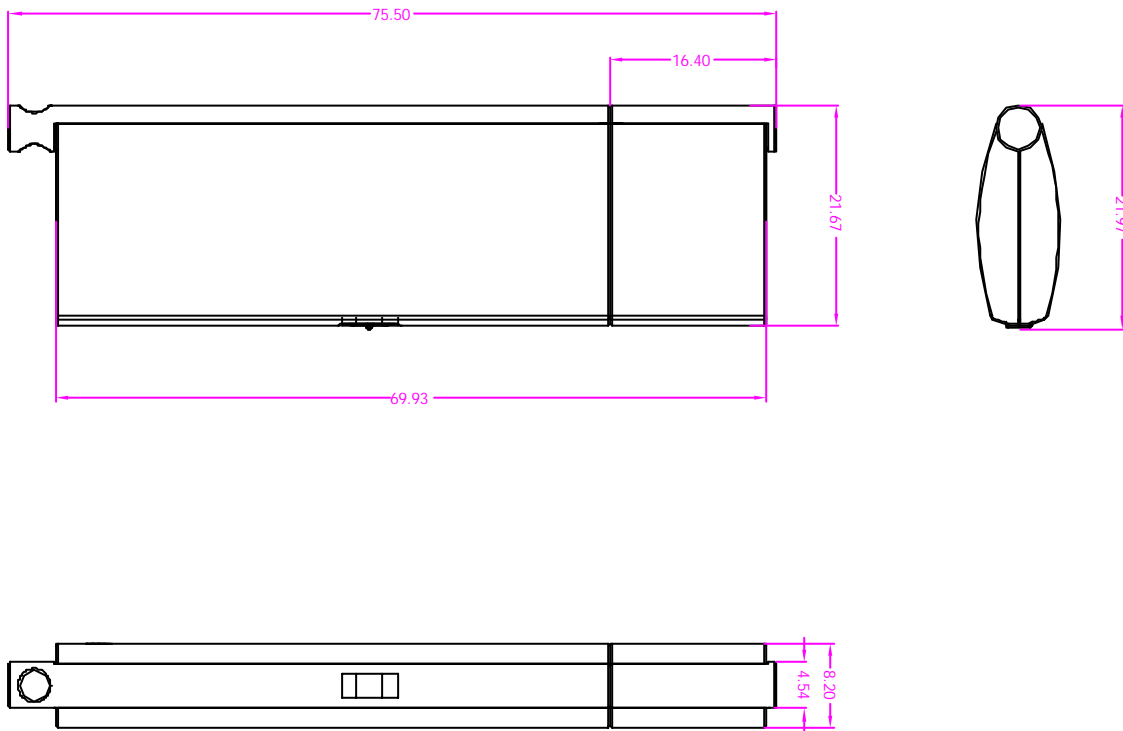

本文件為勤茂資通(股)有限公司專有之財產，非經書面許可，不准透露或使用本文件，亦不准複製或轉變成任何其他形式使用。如有任何修改恕不另行通知

The information contained herein is the exclusive property of TwinMOS Technologies Inc. and shall not be distributed, reproduced, or disclosed in whole or in part without prior written permission of TwinMOS Technologies Inc. TwinMOS Technologies Inc reserved the right to make changes without ant prior notice.

<http://www.twinmos.com>